

M-2iA/3S (Hollow wrist)

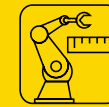

Max. load capacity
at wrist: **3 kg**



Max. Reach:
800 mm

Controlled axes	Repeatability (mm)	Mechanical weight (kg)	Motion range (°)						Maximum speed (°/s)						J4 Moment/ Inertia (Nm/kgm ²)	J5 Moment/ Inertia (Nm/kgm ²)	J6 Moment/ Inertia (Nm/kgm ²)
			J1	J2	J3	J4	J5	J6	J1	J2	J3	J4	J5	J6			
4	± 0.1	120	∅ 800 x 300 *3)			720	-	-	-	-	-	3500	-	-	*4)		

Working Range

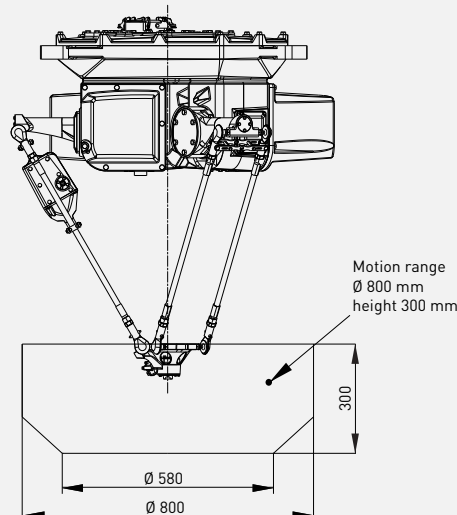
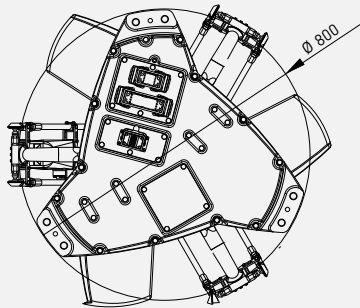

Robot

	M-2iA/3S
Robot footprint [mm]	∅ 800
Mounting position Floor	-
Mounting position Upside down	●
Mounting position Angle	-



Controller

	30iB
Open air cabinet	●
Mate cabinet	○
A-cabinet	○
B-cabinet	-
iPendant Touch	●

Electrical connections

Voltage 50/60Hz 3phase [V]	200-230 *6)
Voltage 50/60Hz 1phase [V]	-
Average power consumption [kW]	2.5

Integrated services

Integrated signals on upper arm In/Out	8/8
Integrated air supply	-

Environment

Acoustic noise level [dB]	73.7
Ambient temperature [° C]	0-45

Protection

Body standard/optional	IP67 / IP69K
Wrist & J3 arm standard/optional	IP69K

*3) ∅ in mm by height in mm *4) refer to the wrist load diagramm *6) transformer required
 ● standard ○ on request - not available () with hardware and/or software option